

THIS IS A C.A.D. GENERATED DRAWING
DO NOT MAKE MANUAL REVISIONS TO MASTER.



ISSUE NUMBER	
ORIGINAL	①
CONDUCTOR & INSULATOR CRIMP FORMS ILLUSTRATION REMOVED, INSTRUCTIONS IN NOTE 4, TABLE DATA REVISED. F. JAWDI FEB. 19,2002	
UPDATED TABLE DATA	③
UPDATED SHEET 2	
K.L.I	AUG. 27,2020

CONDUCTOR CRIMP FORM

INSULATOR CRIMP FORM

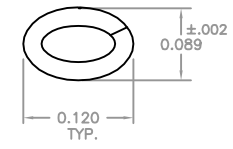
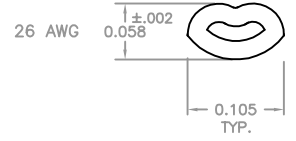
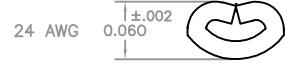
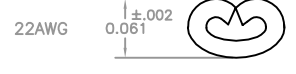
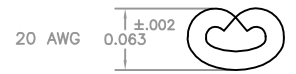
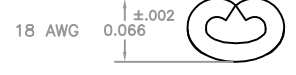
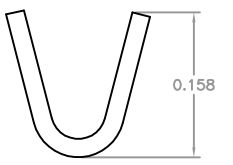
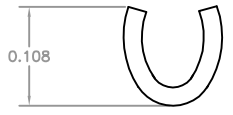

ABOVE CRIMP DIMENSION ARE FOR REFERENCE ONLY

TOOL PART NUMBER: 516-280-201

TO OPEN PARTIALLY CLOSED TOOL
PUSH THIS LATCH IN THE DIRECTION
OF THE ARROW.

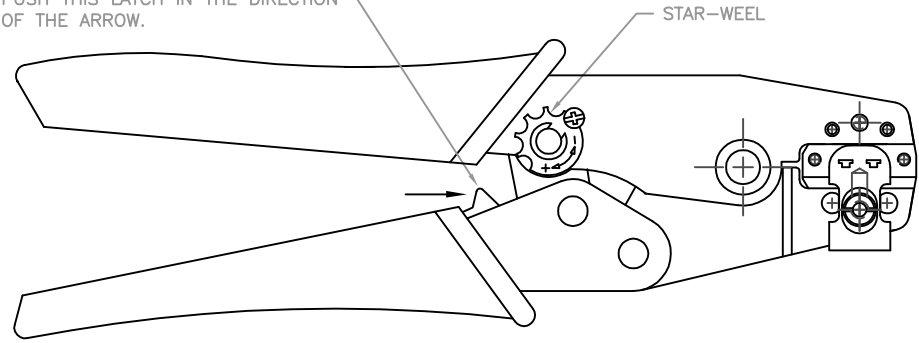

WIRE AWG	CRIMP STRENGTH
18 AWG	40.0 LBS
20 AWG	25.0 LBS
22 AWG	15.0 LBS
24 AWG	10.0 LBS
26 AWG	5.0 LBS
28 AWG	3.0 LBS

NOTES:

- 1- THIS HAND TOOL IS DESIGNED FOR CRIMPING 18 TO 28 AWG WIRES TO EDAC CONTACT P/N 516-290-590 AND 516-294-571
- 2- RISK OF ELECTRIC SHOCK- DO NOT USE THIS ON LIVE WIRE.
- 3- CRIMPING INSTRUCTIONS:
 - OPEN THE TOOL, PLACE THE CONTACT INTO THE CORRECT DIE NEST.
 - PARTIALLY CLOSE THE TOOL UNTIL THE CONTACT IS HELD IN PLACE. INSERT THE WIRE INTO THE CONTACT.
 - CLOSE THE TOOL UNTIL THE RATCHET RELEASES. REMOVE THE CRIMPED CONTACT.
- 4- ADJUSTMENT OF CRIMP FORCE (WHEN NECESSARY):
 - LOOSEN THE SCREW
 - ADJUST THE STAR-WHEEL BY TURNING FROM (-) TO(+).
 - CHECK THE PRELOAD AND THE CRIMP FORCE.

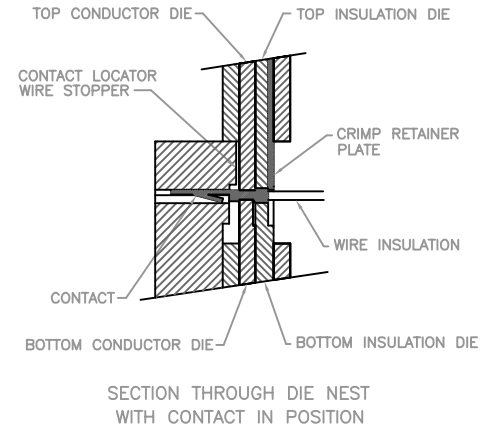

<h2 style="margin: 0;">516 SERIES HAND CRIMP TOOL INSTRUCTIONS</h2>		ACAD REFERENCE NO. 51628211	
		DRAWN: F.BRIONES	DATE: DEC.8/97
<p style="margin: 0;">EDAC INC TORONTO, ONTARIO CANADA</p> <p style="margin: 0;">YOUR CONNECTION TO QUALITY & SERVICE</p>		CHECKED:	DATE:
		SCALE: N.T.S.	SHEET 1 OF 2
		DRAWING NUMBER <b style="font-size: 1.2em;">516-280-201	ISSUE <b style="font-size: 1.2em;">3

THESE DRAWINGS AND SPECIFICATIONS ARE THE PROPERTY OF EDAC INC.,AND SHALL NOT BE REPRODUCED,OR COPIED OR USED AS THE BASIS FOR THE MANUFACTURE OR SALE OF APPARATUS WITHOUT WRITTEN PERMISSION.

THIS IS A C.A.D. GENERATED DRAWING
DO NOT MAKE MANUAL REVISIONS TO MASTER.

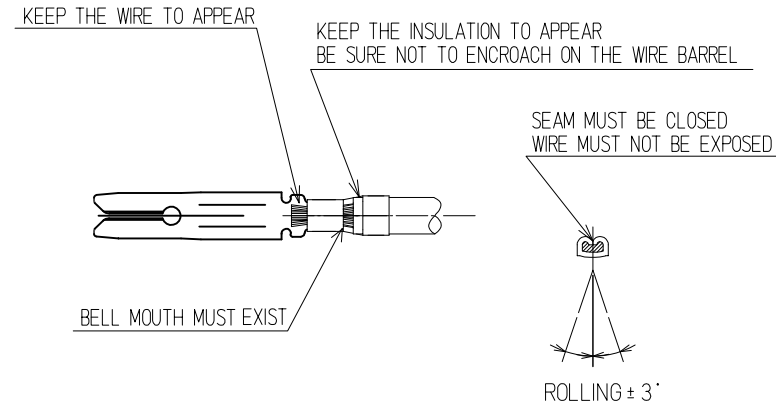
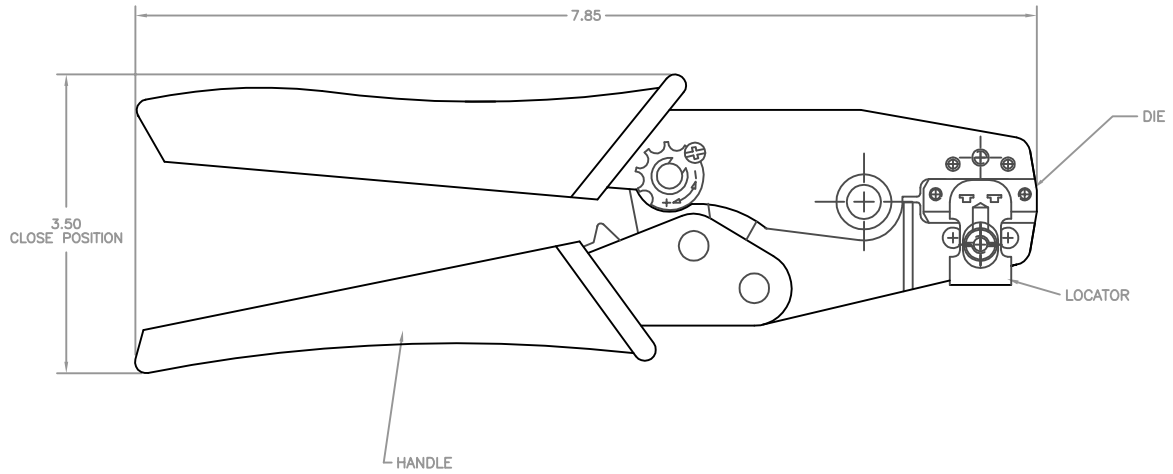

TOOL ASM	LOCATOR
516-280-201	516-280-206

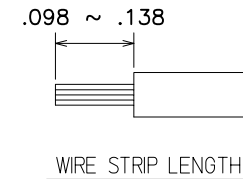

516 SERIES HAND CRIMP TOOL INSTRUCTIONS		ACAD REFERENCE NO. 51628211	
		DRAWN: F.BRIONES	DATE: DEC.8/97
 EDAC INC TORONTO, ONTARIO CANADA YOUR CONNECTION TO QUALITY & SERVICE		CHECKED:	DATE:
		SCALE: N.T.S.	SHEET 2 OF 2
THESE DRAWINGS AND SPECIFICATIONS ARE THE PROPERTY OF EDAC INC.,AND SHALL NOT BE REPRODUCED,OR COPIED OR USED AS THE BASIS FOR THE MANUFACTURE OR SALE OF APPARATUS WITHOUT WRITTEN PERMISSION.		DRAWING NUMBER 516-280-201	ISSUE 3