

THIS IS A C.A.D. GENERATED DRAWING  
DO NOT MAKE MANUAL REVISIONS TO MASTER.

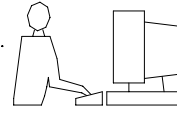

ISSUE NUMBER

ORIGINAL

①

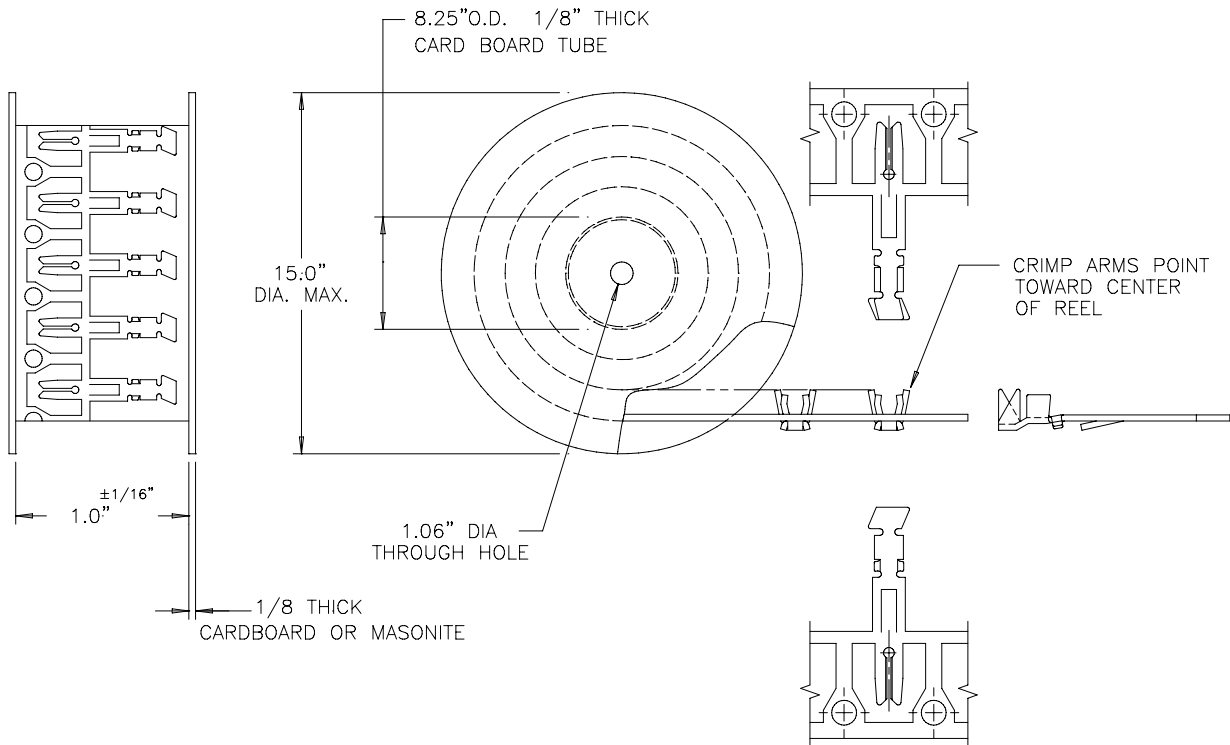

NOTES:

- 1) EACH REEL SHALL CONTAIN A CONTINUOUS STRIP OF 1800 +/-20 CONTACTS. NO BREAKS OR JOININGS PERMITTED IN CONTACT CARRIER. MAXIMUM 2 CONTACTS PER REEL MAY BE OMITTED (CUT AWAY FOR TESTING PURPOSES).
- 2) CONTACTS TO BE WOUND ONTO REEL IN ACCORDANCE WITH ALL VIEWS.
- 3) DO NOT INTERLEAVE PAPER BETWEEN CONTACTS.

PART NUMBER 516-290-591

516 SERIES CRIMP CONTACTS ON REEL  
ORIENTATION-READY FOR CUSTOMER USE

ACAD REFERENCE NO. 51629001

DRAWN: F.BRIONES

DATE: JUNE 4/97

CHECKED:

DATE:

SCALE:

SHEET 1 OF 1

DRAWING NUMBER

516-290-591

ISSUE

1



EDAC INC  
TORONTO, ONTARIO  
CANADA

YOUR CONNECTION TO QUALITY & SERVICE

THESE DRAWINGS AND SPECIFICATIONS ARE THE PROPERTY OF EDAC INC., AND SHALL NOT BE REPRODUCED, OR COPIED OR USED AS THE BASIS FOR THE MANUFACTURE OR SALE OF APPARATUS WITHOUT WRITTEN PERMISSION.